

LINKA BUILDING KIT

LINKA

VILLAGE CHURCH

Before building this model, do become familiar with casting, gluing, and cutting parts, as shown in the 'Basic Instructions'

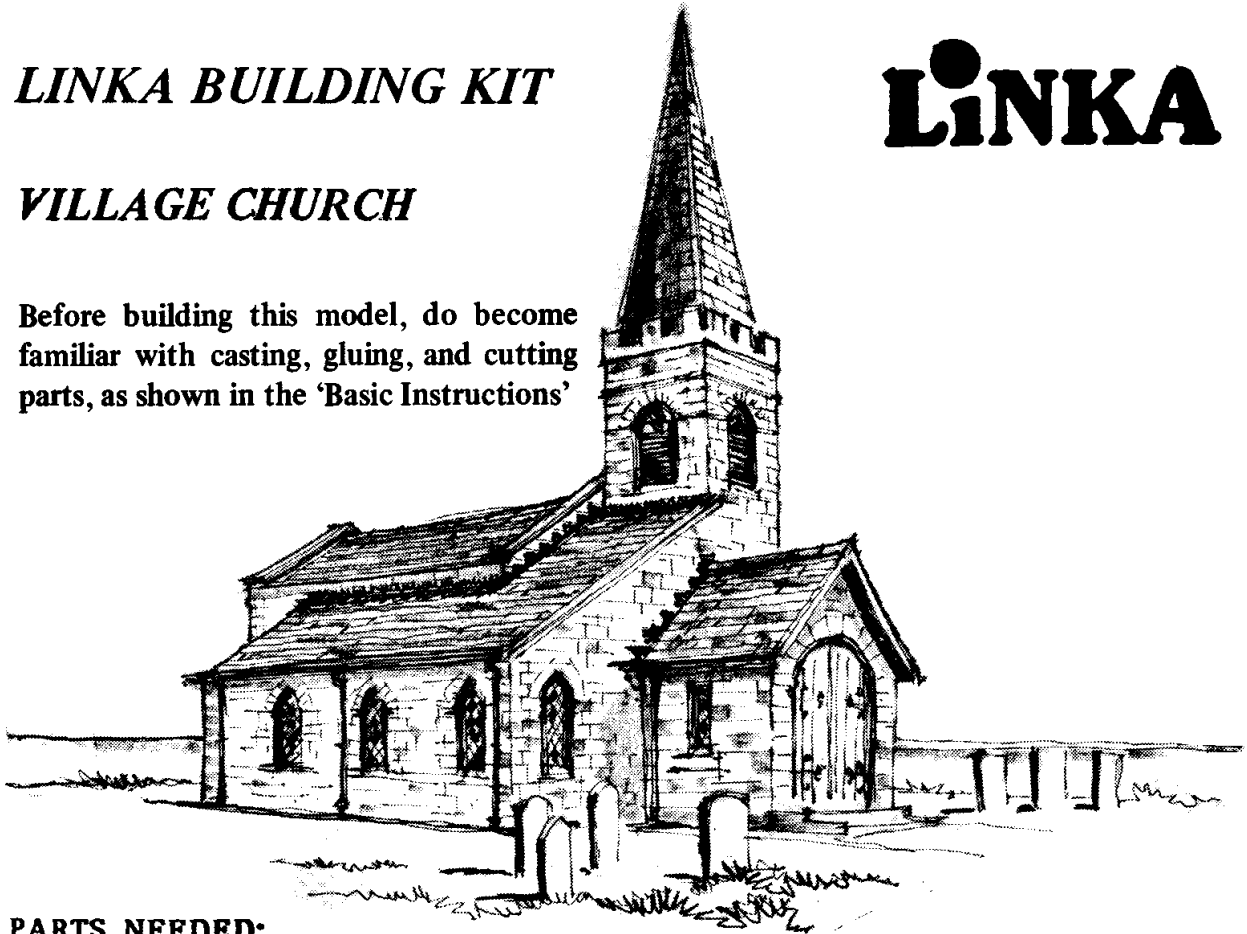

PARTS NEEDED:

There are six moulds in this set. Cast each mould as shown below.

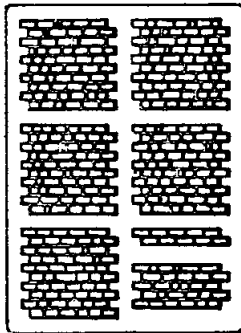

CAST S1 FOUR TIMES

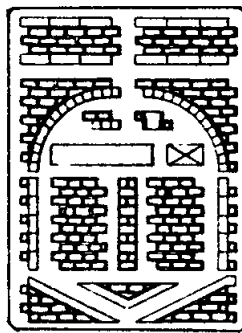

CAST S3 SIX TIMES

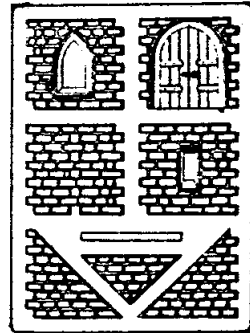

CAST S4 NINE TIMES

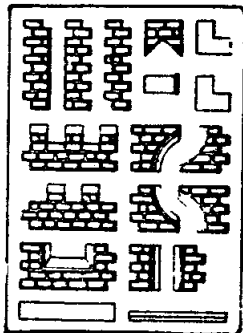

CAST S5 FOUR TIMES

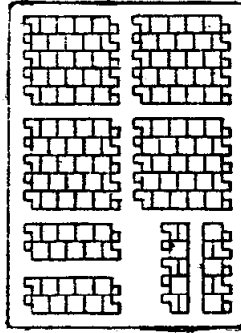

CAST R3 FOUR TIMES

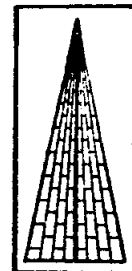

CAST PR5 TWICE

This will produce all the castings needed for this model, as well as a number of spare parts. These spare parts are useful in case you accidentally break any parts during construction, as well as providing extra parts for any variations you may choose to add.

BUILDING THE TOWER:

1) Glue the first four castings together into a square to form the base of the tower.

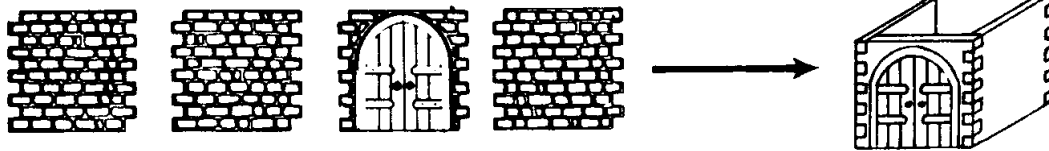

2) Glue the next four castings into another square; glue this square on top of the base, taking care to line up the walls exactly.

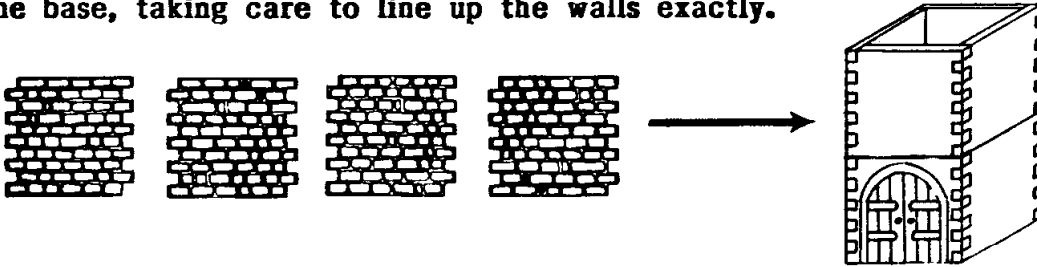

3) Glue the four belfry castings into a square (make sure that the window 'webs' have been removed); glue the belfry to the top of the tower, again lining up the walls carefully.

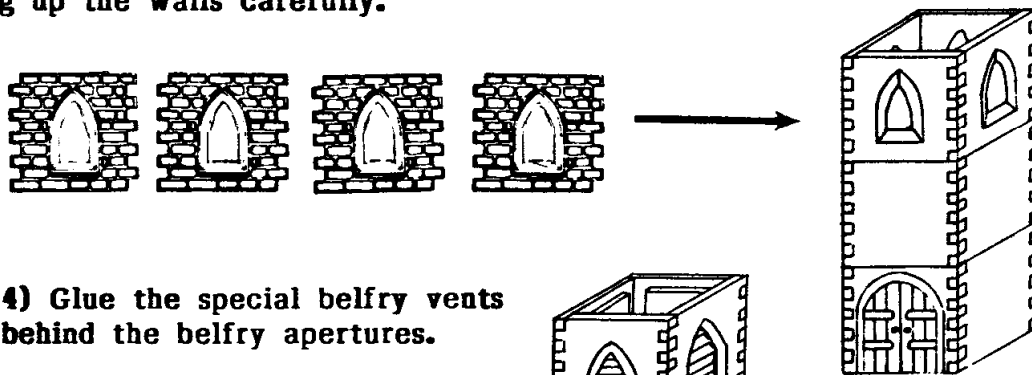

4) Glue the special belfry vents behind the belfry apertures.

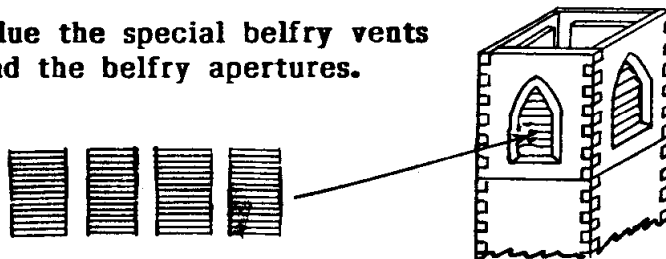

5) Cut the teeth off a standard casting (S1, for example); then glue the panel face down (smooth side up) into the top of the tower to form a platform.

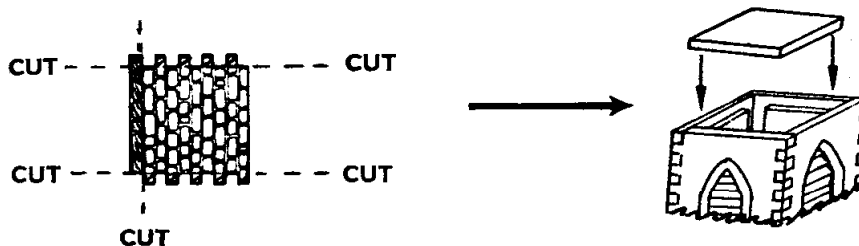

6) Turn the tower upside down; then glue the four small castings shown to the tower base.

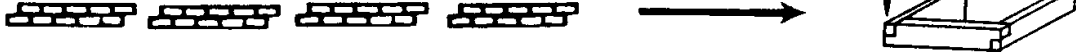

7) Glue the four turret castings into a square; then glue the turret onto the top of the tower.

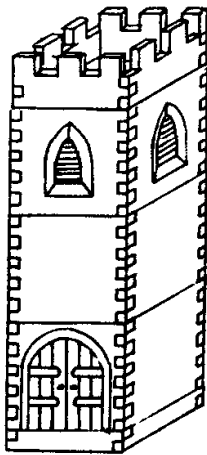
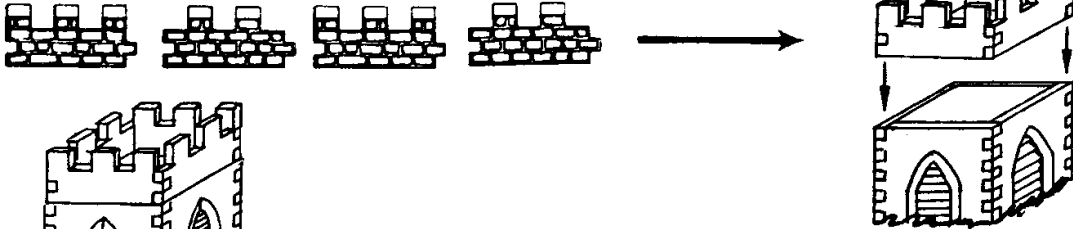

Before the glue hardens fully, check that everything is well aligned; then put the tower safely aside to set completely.

BUILDING THE NAVE:

1) Using the castings shown below, glue the first wall together. When the wall is complete, place face down onto a flat working surface and press all the castings into good alignment before leaving to set. This final lining up of each wall is important, for poor alignment will show up on the finished model.

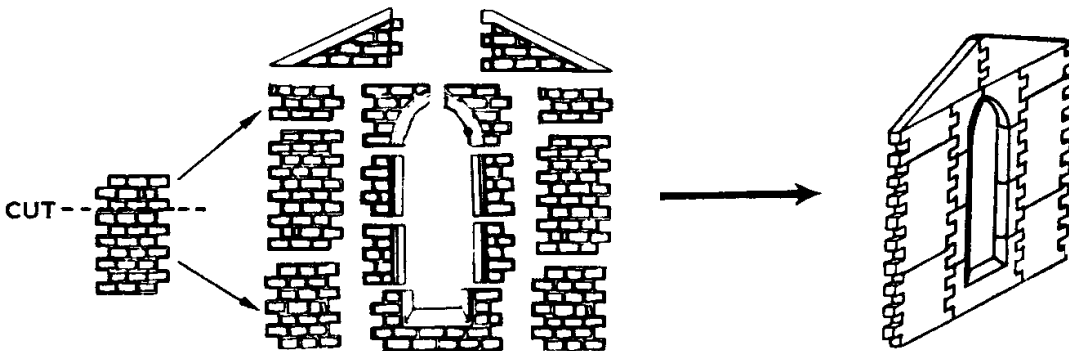

2) Using the castings shown below, glue the opposite end wall together. Note that two of the standard S1 castings need to be cut; glue these cut sections onto the top and bottom of the uncut panels, as shown below. This procedure lines up the teeth correctly for this particular model, which has special window teeth to be matched on the other walls.

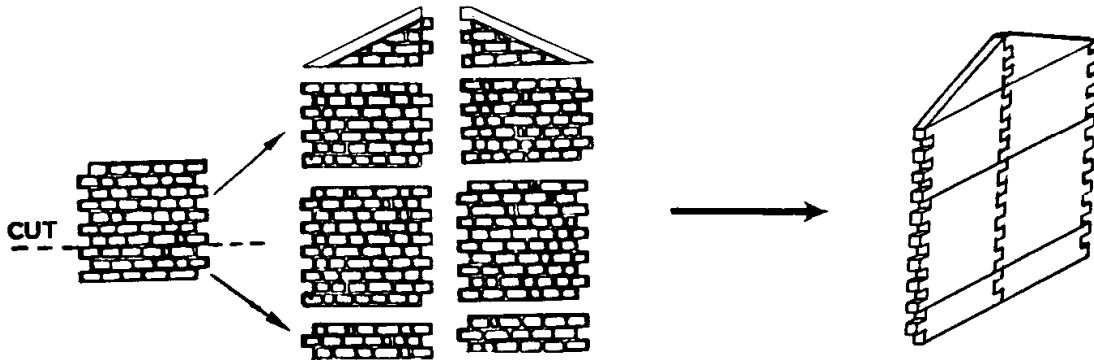

3) Glue together the main side wall with windows. Again, some sections need cutting to line up the teeth correctly.

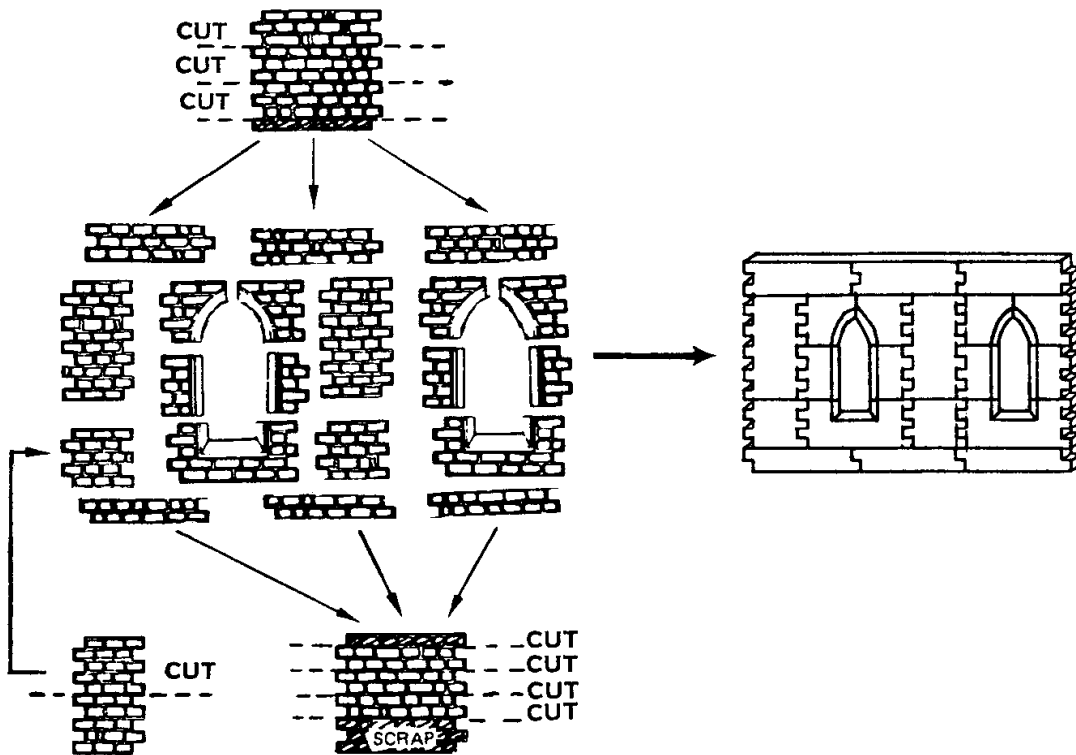

4) Glue together the opposite side wall, using the parts shown below:

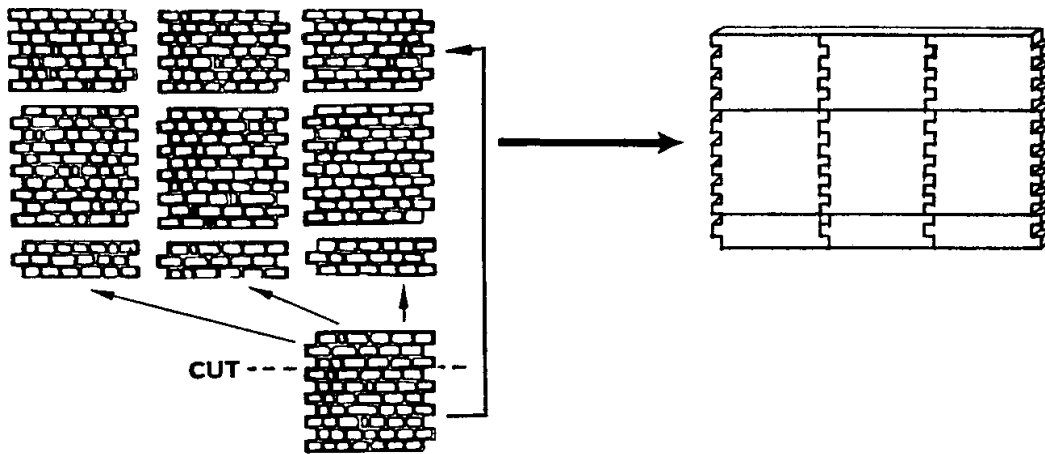

5) When set, glue the four sides together, one wall at a time, carefully easing the teeth from one wall into another. Try to be careful; but don't worry if some teeth break off during this tricky operation, as broken teeth can be glued back into place. (Any fracture line will become invisible after the model has been painted.)

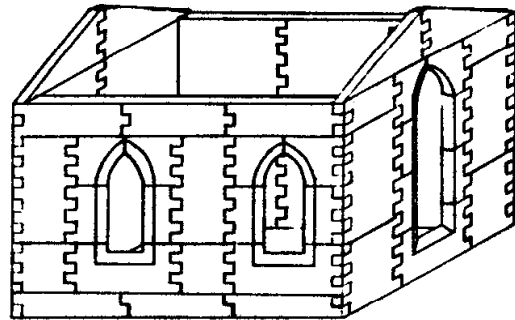

6) The nave roof is recessed and will require supports to rest upon. Glue the roof supports (triangular castings from S5, or any thin scrap offcuts) onto the inside of the completed nave, a little below the roof line, as shown below.

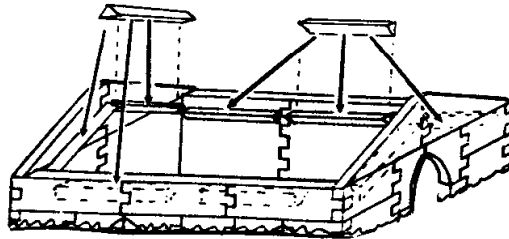

7) Glue one side of the nave roof together as shown below.

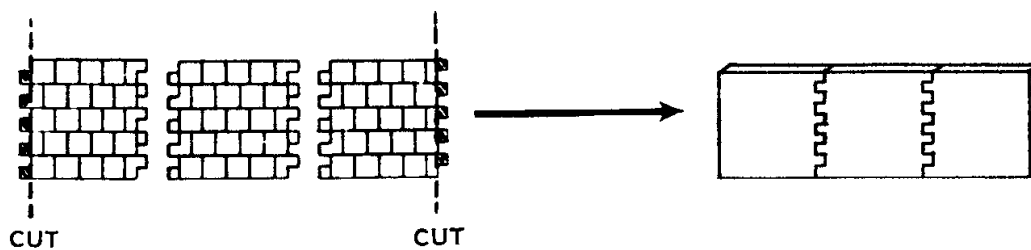

Repeat, exactly the same, for the other side.

8) Glue the two roof sections into the top of the nave walls, resting them on the roof supports. Glue the metal ridge tiles supplied onto the apex, cutting as needed. Check alignment; then set the nave safely aside so that the glue can dry completely.

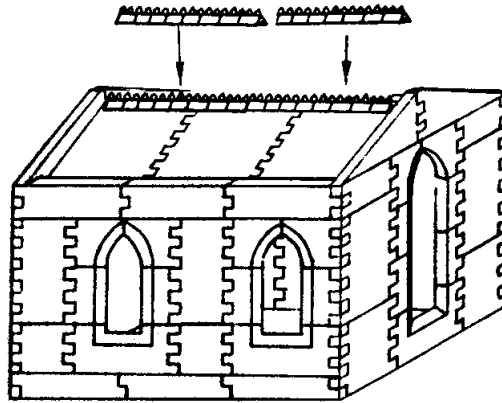

BUILDING THE SIDE AISLE:

1) Glue the side wall together.

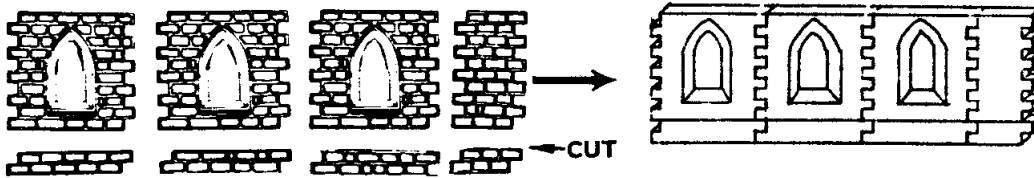

2) Glue the front wall together.

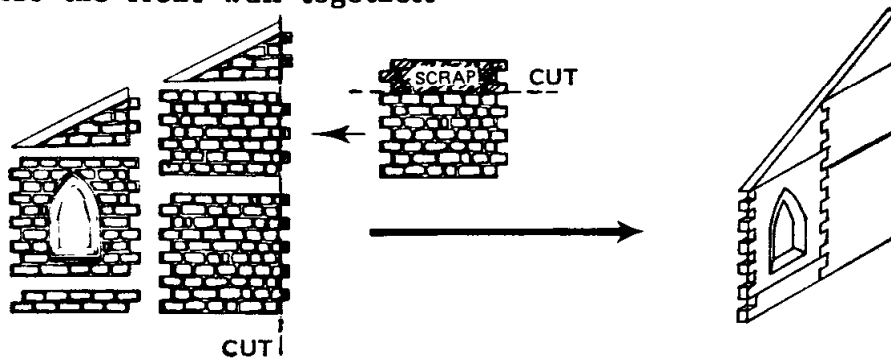

3) Glue the back wall together.

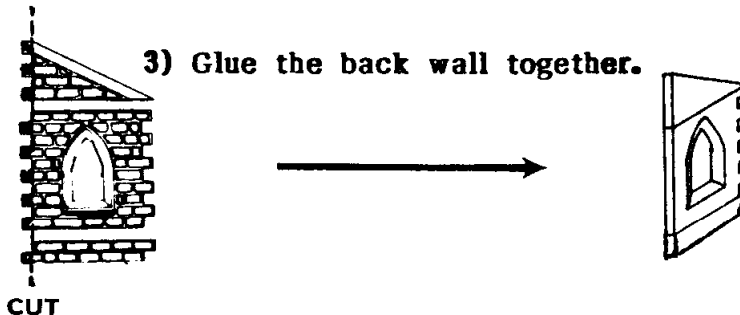

4) Glue the three wall sections carefully together, check alignment, then put aside so that glue can set completely.

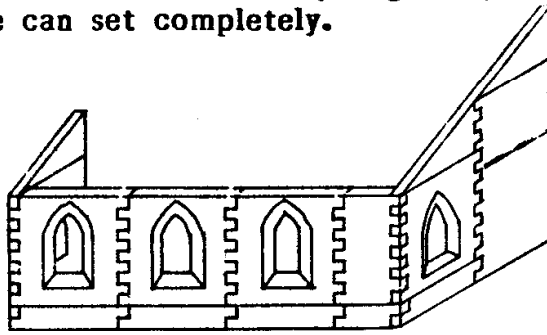

ASSEMBLING THE MAIN CHURCH:

1) Glue the tower to the nave (the 'blank' end of the nave, not the 'window' end) with the tower door in line with the nave side windows, as shown below.

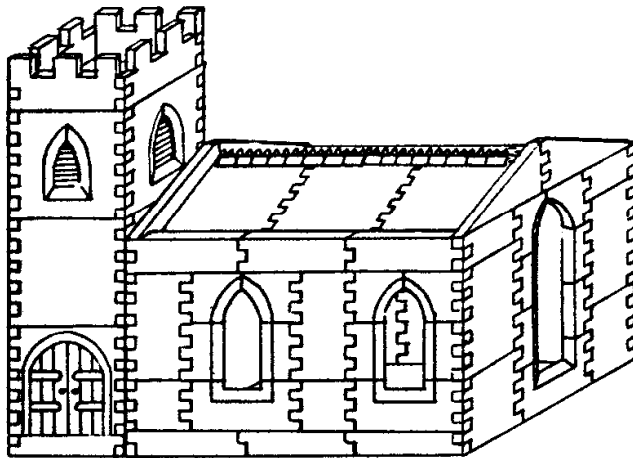

2) Glue the side aisle walls to the other side of the church, as shown below.

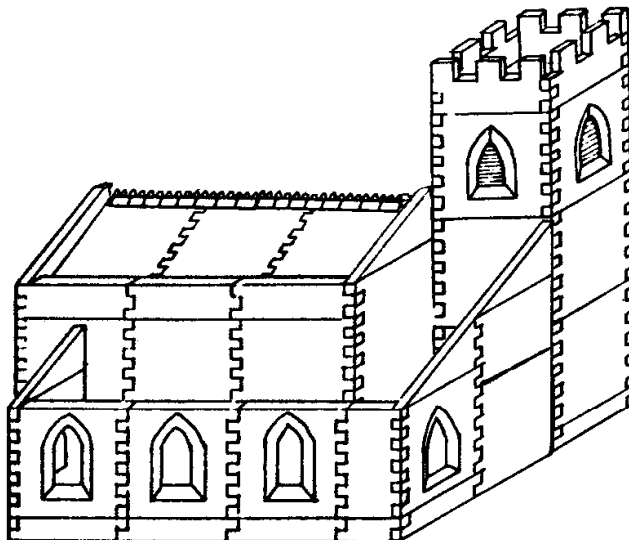

3) Glue the side aisle roof together.

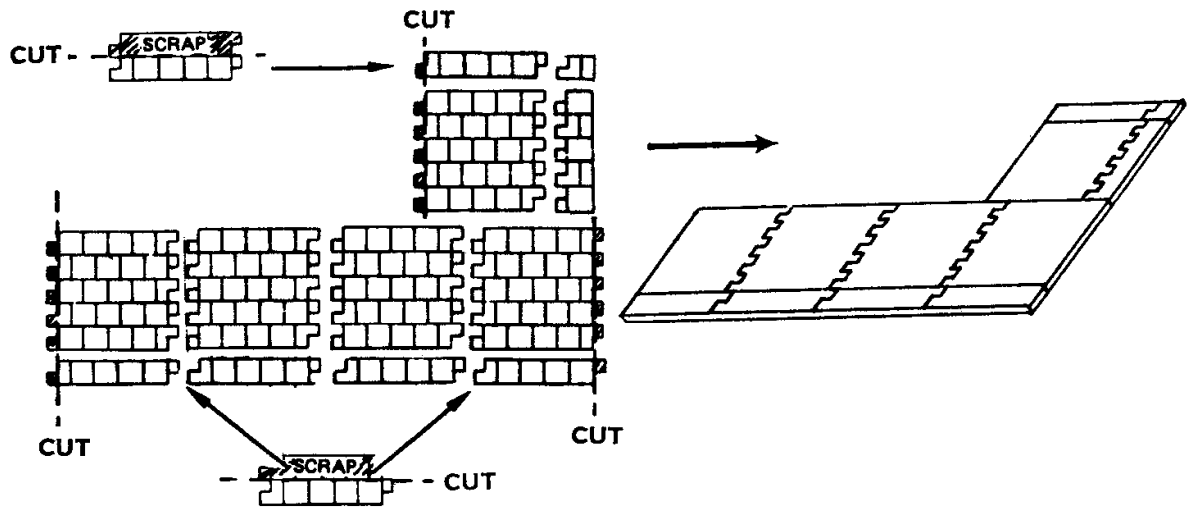

4) Glue the side aisle roof into place on the model. You will have to sand the top edge of the roof to achieve a snug fit against the church tower.

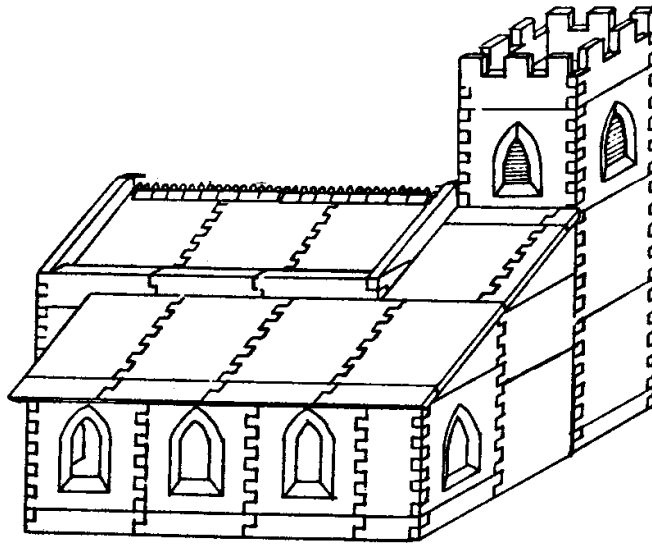

BUILDING THE FRONT PORCH:

1) Glue together the castings shown below to form the front porch.

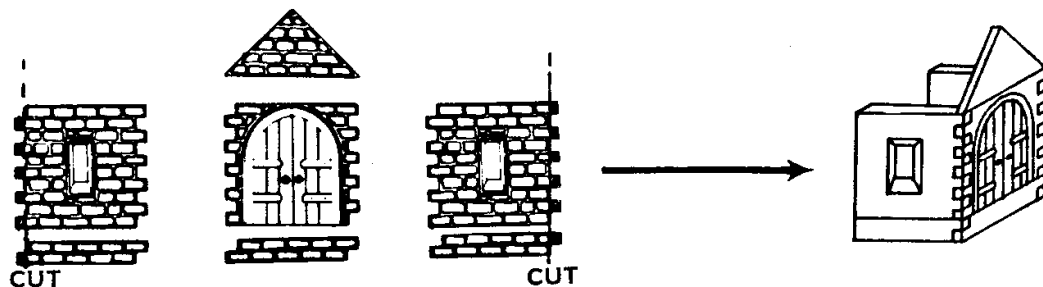

2) Add the porch roof, and metal ridge tiles.

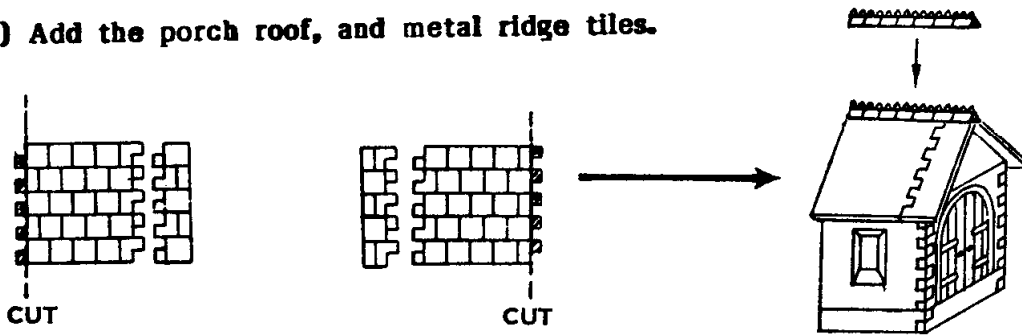

3) Glue the completed porch onto the church front.

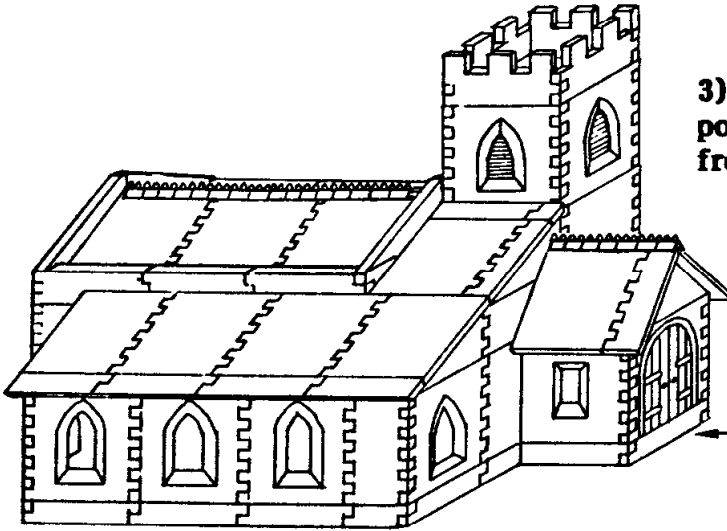

ADDING STEPS:

Steps are made from strips of standard castings, cut to appropriate widths, glued together (smooth side up) and sanded as needed. Use a double step for the front door and a single step for the side door in the tower.

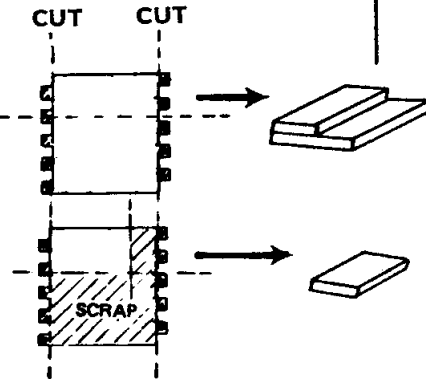

ADDING THE STEEPLE:

The steeple is optional; but if you wish to add it, take two castings from the special PR5 Steeple mould and glue them together to form a square. When dry, chamfer the bottom of the steeple, so it will fit inside the tower. (Carve with a craft knife, then sand, for a snug chamfer.)

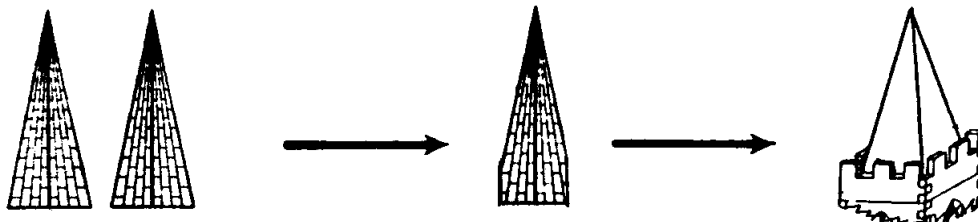

PAINTING AND ADDING WINDOWS:

The model is now ready for painting. Many model paints can be used for painting Linka models, with pots of enamel or acrylic paints (such as "Humbrol", available from most model and craft stores) being popular. For brick and stonework, etc, use a matt paint; for doors, window frames, gutters, drainpipes, etc., use a gloss paint.

You should find the painting both interesting and straightforward, as the castings take paint well, with the crisp detail helping to guide your brush.

The exact shades and colours to be used are up to you, as stone and slate vary greatly in hue. You may find it helpful to refer to the coloured illustration on the box. A colour guide is also included in this kit.

1) Paint all stonework with your chosen stone colour, then all roofing with your chosen slate colour.

2) Once this first coat of paint is dry, check the model for any gaps or ill fitting joints. Fill any gaps by making a very weak mix of Linka moulding compound (about $\frac{1}{2}$ teaspoonful of compound to 3 teaspoonful of water) and paint this mix into the gaps with a small paintbrush. An old toothbrush is useful for cleaning off any excess mix, as well as cleaning out any detail that may have been inadvertently covered. Repaint with stone or slate colour as needed.

3) Paint the doors gloss brown. Pick out the hinges in black.

4) When dry, cut out windows from the window sheet supplied, and glue in place behind the window apertures of the model. Try to keep the surfaces of the windows free from glue.

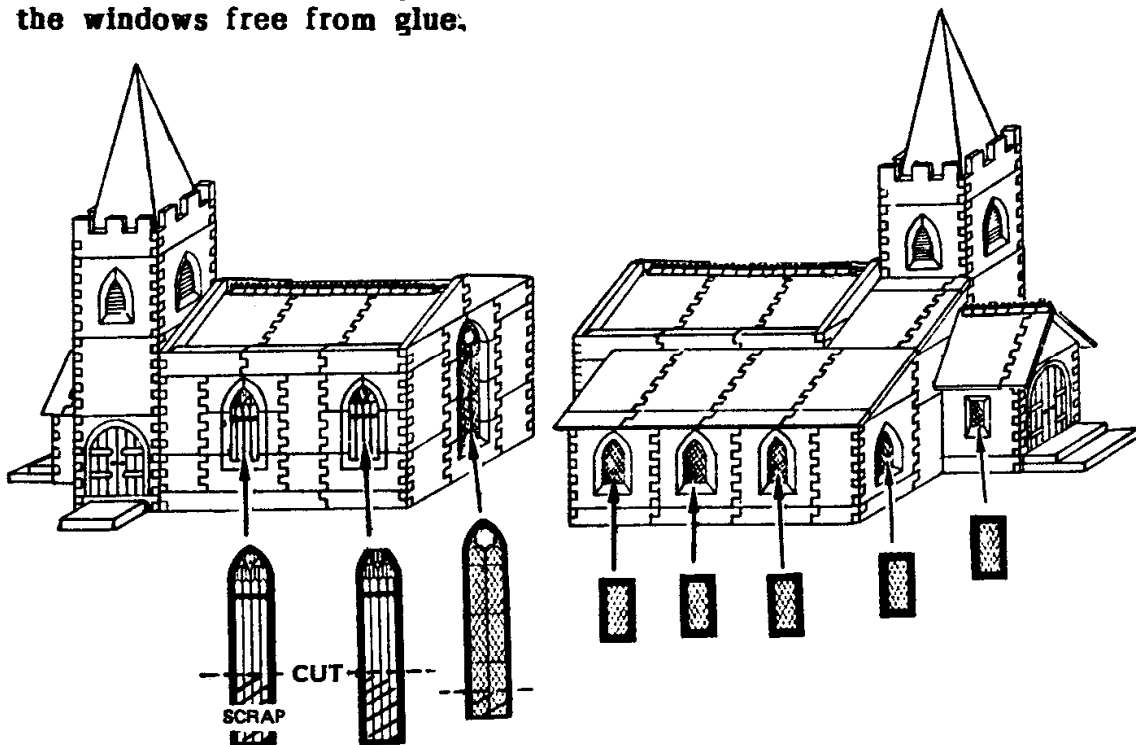

5) For greater realism, pick out various stones in different shades of stone colour: mix a little palette of stone colour, then add small dabs of red or yellow to give different shades of stone. This can be applied at random to various stones around the model. Do this two or three times with different shades. Repeat the process with varying shades of slate colour on the roof.

ADDING GUTTERS & DRAINPIPES:

1) Prepare the underside of the side aisle roof for guttering by sanding the bottom edge horizontal, as shown below.

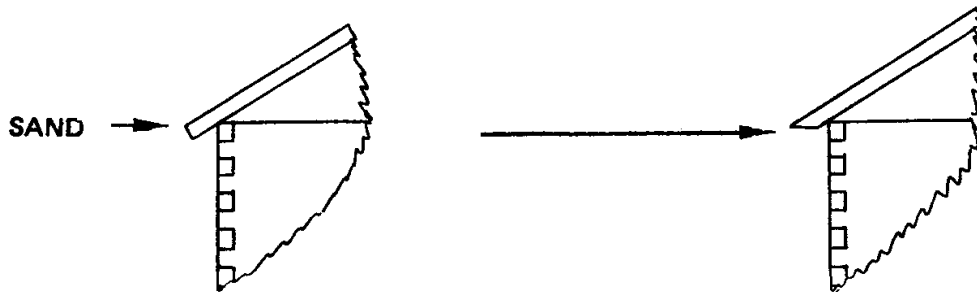

2) Cut a piece of plastic guttering to the length of the side aisle roof; then glue in place under the eaves.

3) Cut two pieces of plastic drainpipe to the height of the side aisle wall; bend as shown; then glue in place under the guttering.

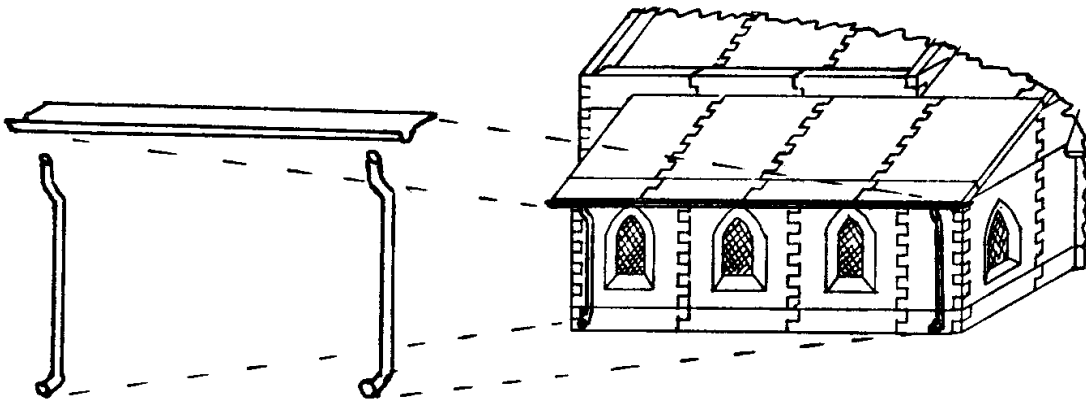

4) Glue the three rain hoppers to the main nave wall as shown; then glue three lengths of drainpipe, bending as shown, to the nave wall, below the hoppers.

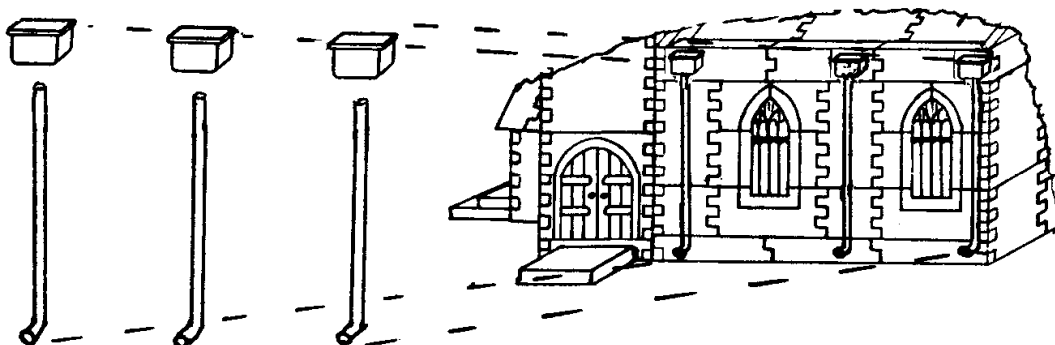

FINISHING:

For the final finishing and weathering of the model, switch to watercolour paint, in either powder, tube or block form. With a well diluted mix of grey watercolour, paint the entire stonework area; when dry, some of the paint will have collected in the mortar runs to represent cement. If it has 'greyed' the stonework too much, sponge off the excess. Repeat with a black wash for the roof. This process can be repeated for heavier weathering effects, or washed off and re-applied for any change of effect.

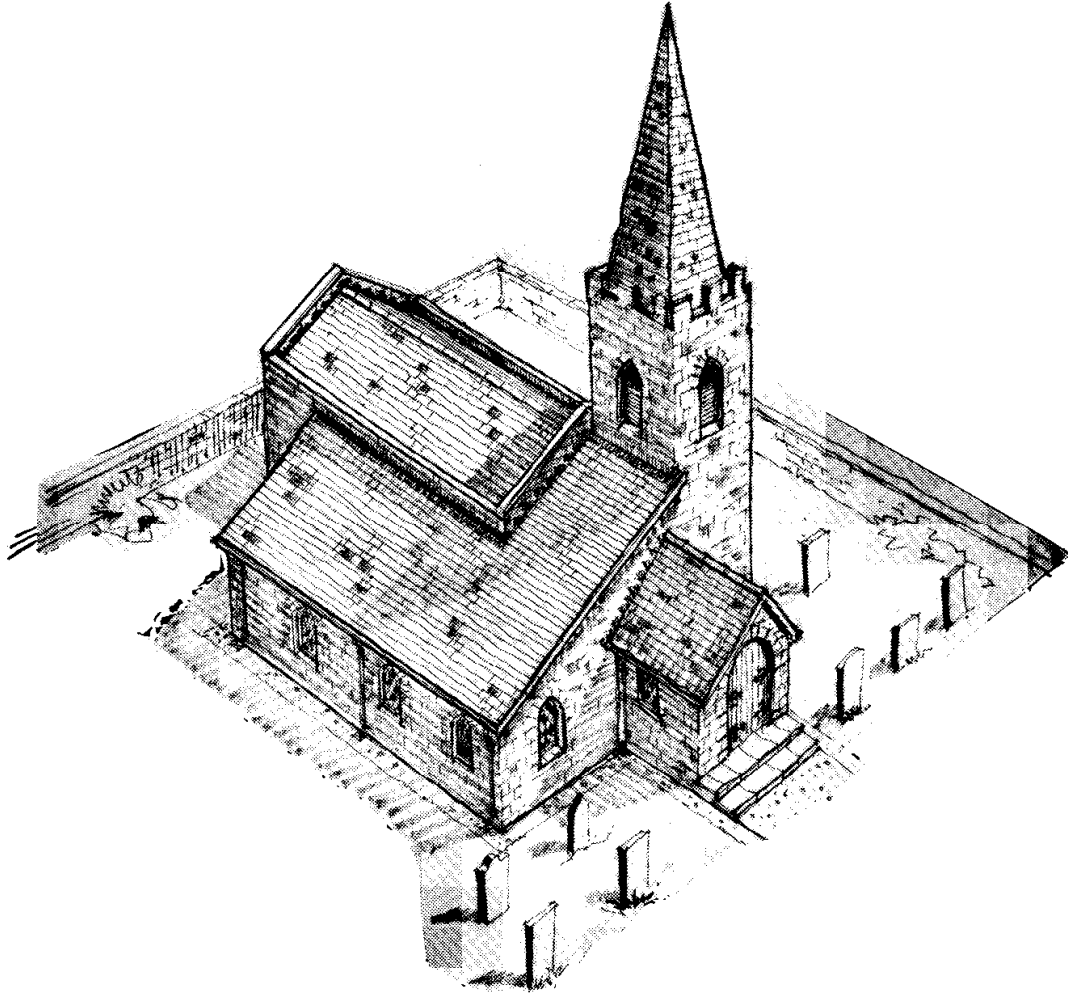

Adding a churchyard setting for the completed church can be fun - casts from moulds S1 and S3 can be used for the walls and coping, and scrap parts sanded to represent gravestones. A scenic kit of materials for grass, gravel and foliage is available from Linka.

THE WORLD OF LINKA

We hope you have enjoyed this kit. It is one of a large and varied range available, with many fascinating accessories and features - build up a collection with this absorbing hobby.